

F# pentatonic major (5-String Banjo Tuning)

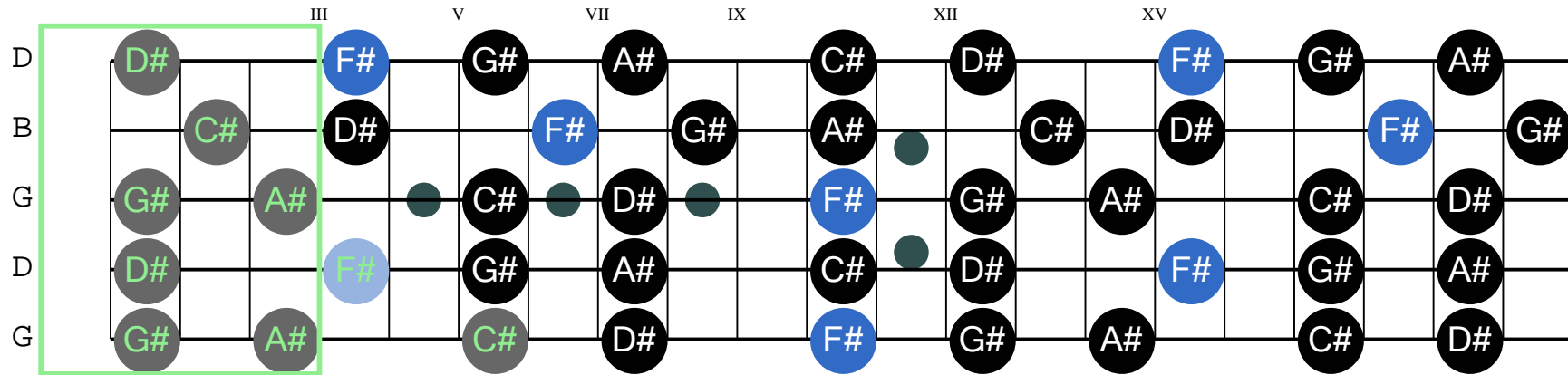

The musical notation consists of three staves. The top two staves are guitar-style staves with fret numbers: 1, 3, 6, 1, 4, 1, 3, 2, 1. The bottom staff is a standard musical staff with a treble clef and a key signature of two sharps (F# and C#). The notes are: F# (III), G# (III), A# (III), F# (V), G# (V), A# (V), C# (VII), D# (VII), E# (VII), C# (IX), D# (IX), E# (IX), F# (XII), G# (XII), A# (XII), F# (XV), G# (XV), A# (XV).

Note: Octave may be adjusted to better fit staff.